

SL714-16KHD

7' x 14', 16,000 lbs. Heavy Duty Tandem Axle Dump Trailer



Standard Features

- 168" Inside Box Length
- 26" Wall Height
- 82" Inside Box Width
- 7 GA Floor
- Aluminum Slide-In Ramps (4,000 lbs. Midspan)
- Spare Tire Carrier
- Welded Fenders
- Stake Pockets & Rub Rails
- Tarp
- Slam Lock, 3-Way Tailgate
- 12,000# Hydraulic Jack
- Aluminum Toolbox w/ LED Light, Charging System, Removable
- Tray, and Magnetic Remote Holder
- Breakaway Kit
- All Enclosed Wiring
- LED Lighting Package
- Bolt-on Safety chains & Hooks
- Lippert Equa-Flex Axles
- Radial 12 Ply Tires
- Steel Component cleaned with Steel Shot Blast
- PPG Paint with Two Way Hardener

Specifications

Tailgate:	3 Way Tailgate/Slamlock	Coupler:	2 5/16" – 6 Hole Adjustable
Lights:	L.E.D. DOT Stop, Tail, Turn, & Clearance	Tires:	ST235/85R 16 F
Suspension:	Multi-Leaf Spring w/ Equalizer	Rims:	16 x 6; Steel 8 Bolt
Safety Chains:	16,200# 3/8" x 35" w/Clevis Slip Hook	Brakes:	Electric
Jack:	12,000 lbs. Hydraulic	Frame:	6" x 2" HSS Tube
Hoist:	13 Ton Double Acting Hydraulic Scissor Hoist	Crossmember:	Engineered Sill Design
Fenders:	75.875" x 9" x 10", 14 GA Checkerplate	Tongue:	6" x 2" HSS Tube
Floor:	7 GA Steel Sheet	Electric Plug:	7 Wire RV Plug
Axle:	(2) 8000# w/ Electric Brakes	Electric Plug:	10 GA Steel Sheet

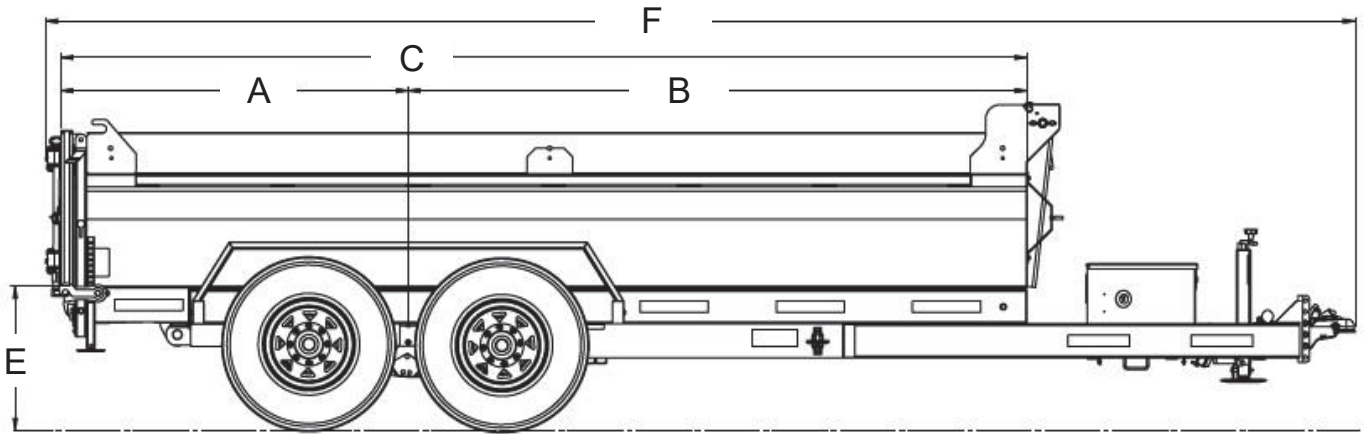

Dimensions

Model	A	B	C	D	E	F
SL714-16KHD	61 3/16"	109 1/16"	170 1/4" x 84"	N/A	25 5/16"	230 13/16"

Model	Description	Net Weight	GVWR	Payload Cap.
SL714-16KHD	7' x 14' 16,000 lbs. Tandem Axle Black/Charcoal	3,791 lbs.	17,120 lbs.	13,329 lbs.

Standard Parts

Part# 2028 – AXLE 80-865E 93.0" X 79.0" STR EYE TO EYE U/S

Part# 2440 – LIGHT LICENSE PLATE SURFACE MOUNT MINI CHROME - LED

Part# 51105 – JUNC BOX AND 6FT LEAD PACKAGE

Part#57637 – LIGHT STOP TURN TAIL RED 6.5" X 2.5" OVAL LED – 10 DIODE

Part# 1879 – BREAKAWAY SWITCH C/W PULL PIN

Part#87997 – TOOLBOX ALUMINUM TRAILER TONGUE STYLE W/ GAS SHOCK

Part# 843 – COUPLER CHANNEL MOUNT 22,000# 2.3125" - W/ 6 HOLE CHANNEL & HARDWARE

Part#76835REV1 – RAMP ALUMINUM 6FT CHANNEL SLIDE UNDER

Part# 77748 – FENDER TANDEM STEEL 75.875" X 9" X 10" - 14 GA CHECKERPLATE

Part#51126 – HYDRAULIC POWER UNIT 12V ELECTRIC DUAL DOUBLE ACTING

Part# 4375 – SL280 HYD JACK PACKAGE

Part# 71384 – TARP 6.5' X 18.0' C/W HARDWARE KIT

Part# 1329 – LIGHT CLEARANCE AMBER 0.6875" ROUND LED W/ GROMMET

Part# 55961 – TIRE ASSEMBLY 235/85R16 F 12 PLY 8 HOLE BLACK (5/8" STUDS) #3960

Part#1332 – LIGHT CLEARANCE RED 0.6875" ROUND LED W/ GROMMET



Specs are subject to change without notice. Please contact Southland Trailer Corp Product Specialist for price confirmation on all Products. - Revised February 2023